

INSTALLATION INSTRUCTION FOR SF-SVRTBAR SERIES SURFACE VERTICAL ROD EXIT DEVICE.

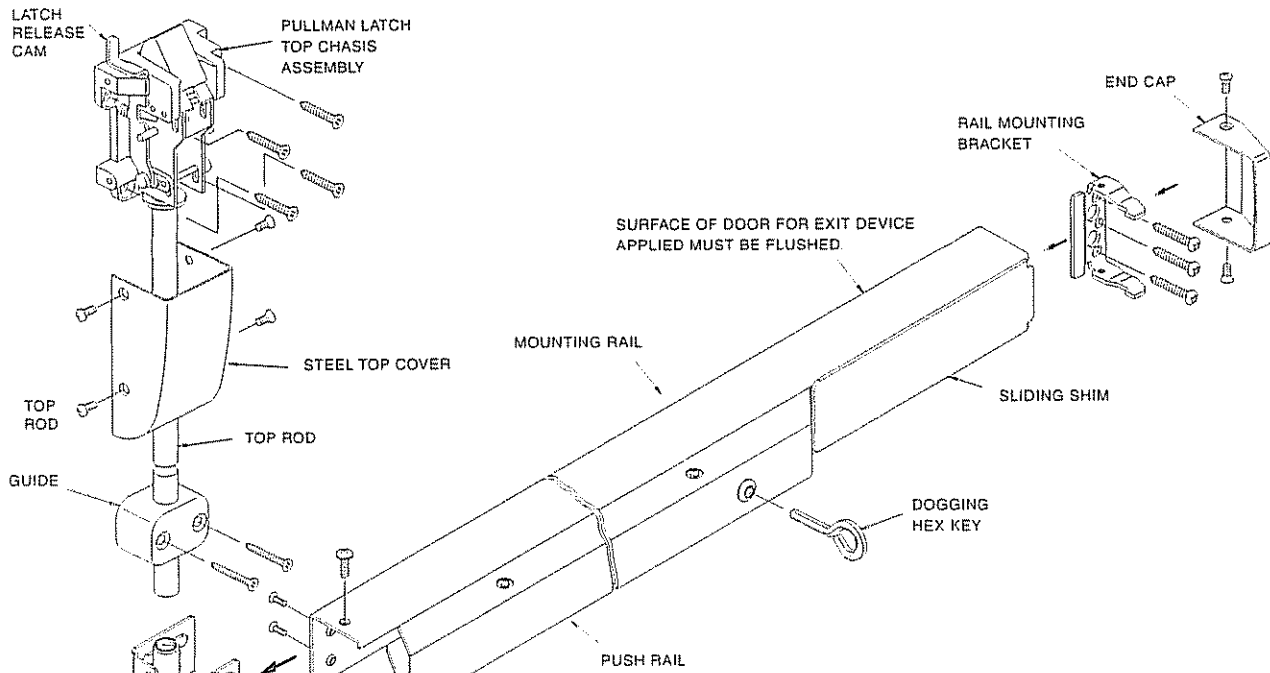

To change hand

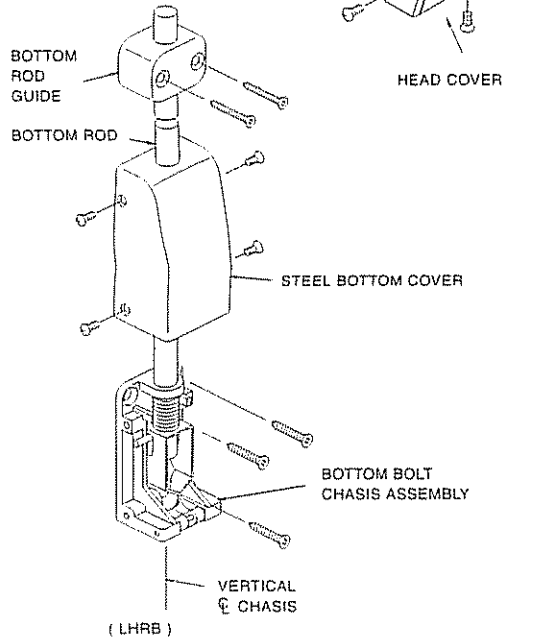
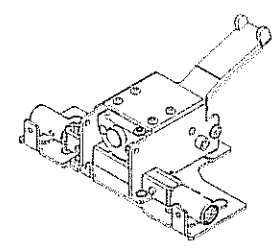
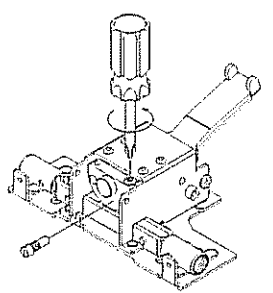
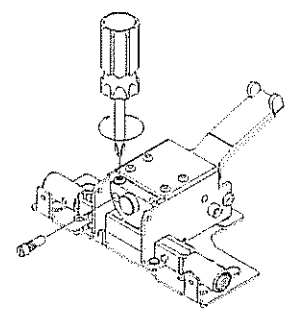
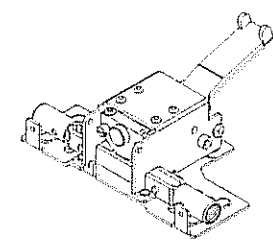

1.Factory pre-set RHR	2.Unfasten philip and flat head screw from the pre-set RHR
	
3.Fasten philip and flat head screws to the other end for LHR	4.Now already changed to LHR
	

1. MARK VERTICAL AND HORIZONTAL REFERENCE LINE ON DOOR.

DETERMINE BACKSET TO LOCATE VERICAL REFERENCE LINE

- 1 IF LOCK STILE IS 4 1/2" WIDE OR WIDER, BACKSET IS 2 3/4"
- 2 IF LOCK STILE IS LESS THAN 4 1/2" WIDE, BVACKSET IS HALF OF THE EXPOSED WIDTH OF LOCK STILE

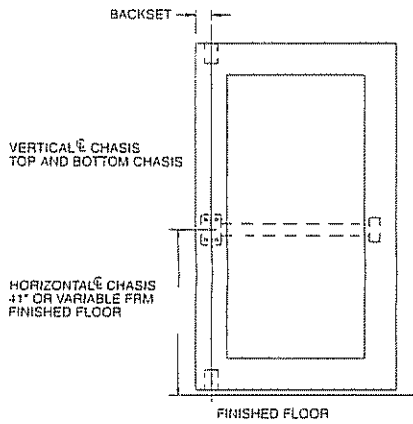

4. ATTACH TOP AND BOTTOM CHASIS

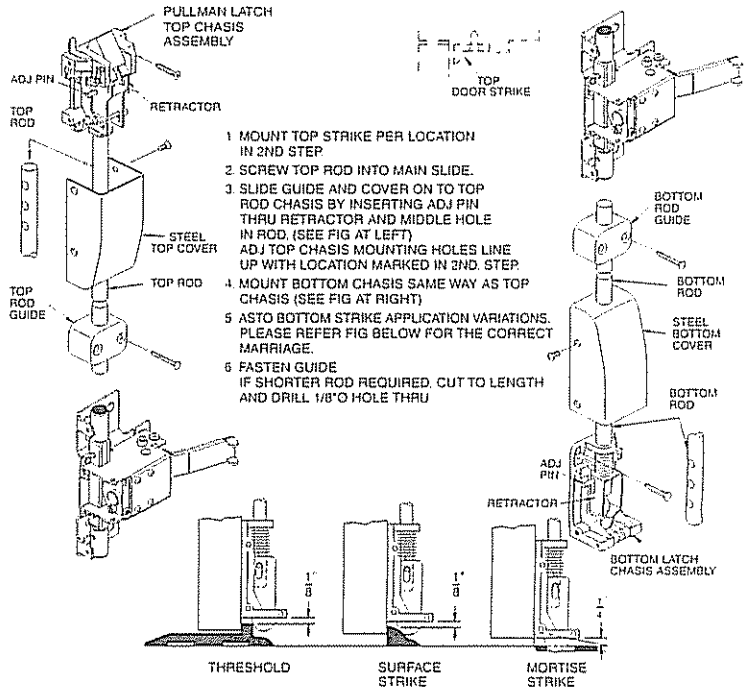

2. PREPARE DOOR

TAPE TEMPLATE ON INSIDE OF DOOR ALONG REFERENCE LINE SPOT AND DRILL HOLE

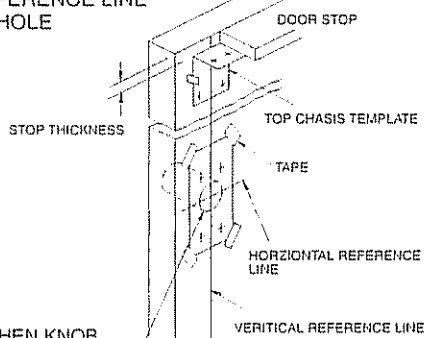

2 1/8" O BORE WHEN KNOB AND LEVER TRIM IS USED

5. APPLY RAIL ASSEMBLY

1. CHECK THE SIZE OF DEVICE. IF CUTTING TO LENGTH IS REQUIRED.
- 2 DETERMINE CUT OFF LENGTH "X" BY SUBTRACTING 1 3/4" FROM "Y" MARK CUT OFF POINT ON MOUNTING RAIL.

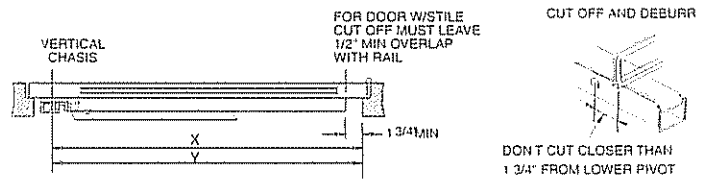

- 3 DREPRESS ARM INTO RAIL OPENING AND SLIDE RAIL ONTO CHASIS LEVEL RAIL AND FASSTEN CHASIS AND MOUNTING PLATE

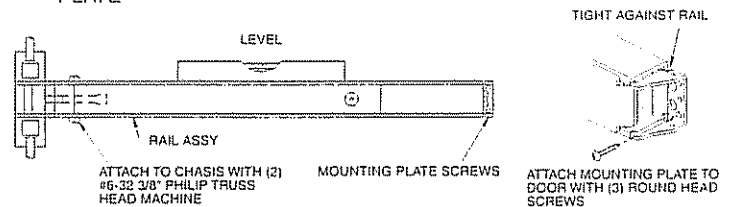

3. APPLY TRIM+CHASIS

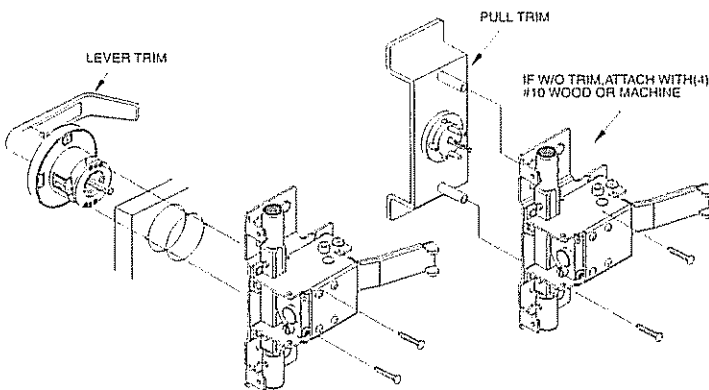

BEFORE INSTALLING DEVICE, PLEASE CHECK :

- 1 IF DOOR FITTED AND HUNG
- 2 SIZE OF EXIT DEVICE, FUNCTION AND DESIGN..
 - 2 1 36" DOORS. CAN BE CUT TO FIT DOORS DOWN TO 30" WIDE
 - 2 2 48" DOORS. CAN BE CUT TO FIT DOORS DOWN TO 36" WIDE
 - 2 3 HAND OF DEVICE AGAIST APPLICATION



- 3 TO CHANGE HAND OF DEVICE
 - 3 1 USE PIN, 2 1/4" LONG, TO KNOCK OUT LIFT LEVER PIN.
 - 3 2 REMOVE LIFT LEVER AND REASSEMBLE OTHER END

6. APPLY COVER

CHECK FINAL OPERATION OF DEVICE AND ADJUST THEN FASTEN COVERS

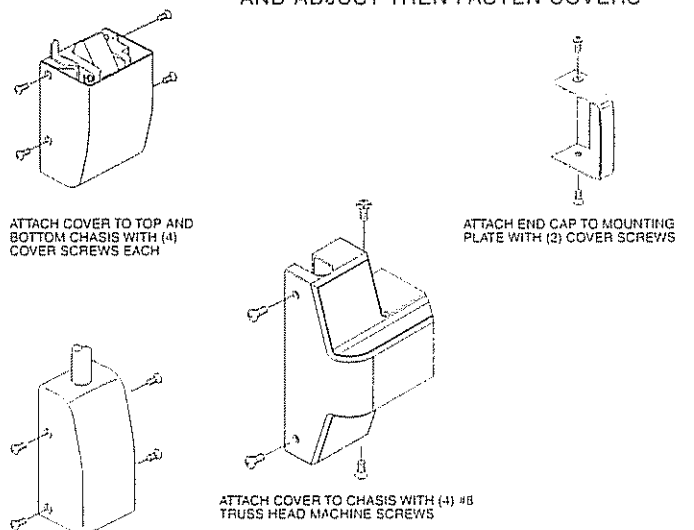

TEMPLATE

FOR EDTBAR AND SVRTBAR SERIES EXIT DEVICE
USING LEVER HANDLE TRIM

FOR WOOD DOORS :
DRILL(4) 3/32" DIA. X 1-1/4"
DEEP PILOT HOLES
FOR METAL DOORS :
TAPPED(4) #3/16" HOLES.

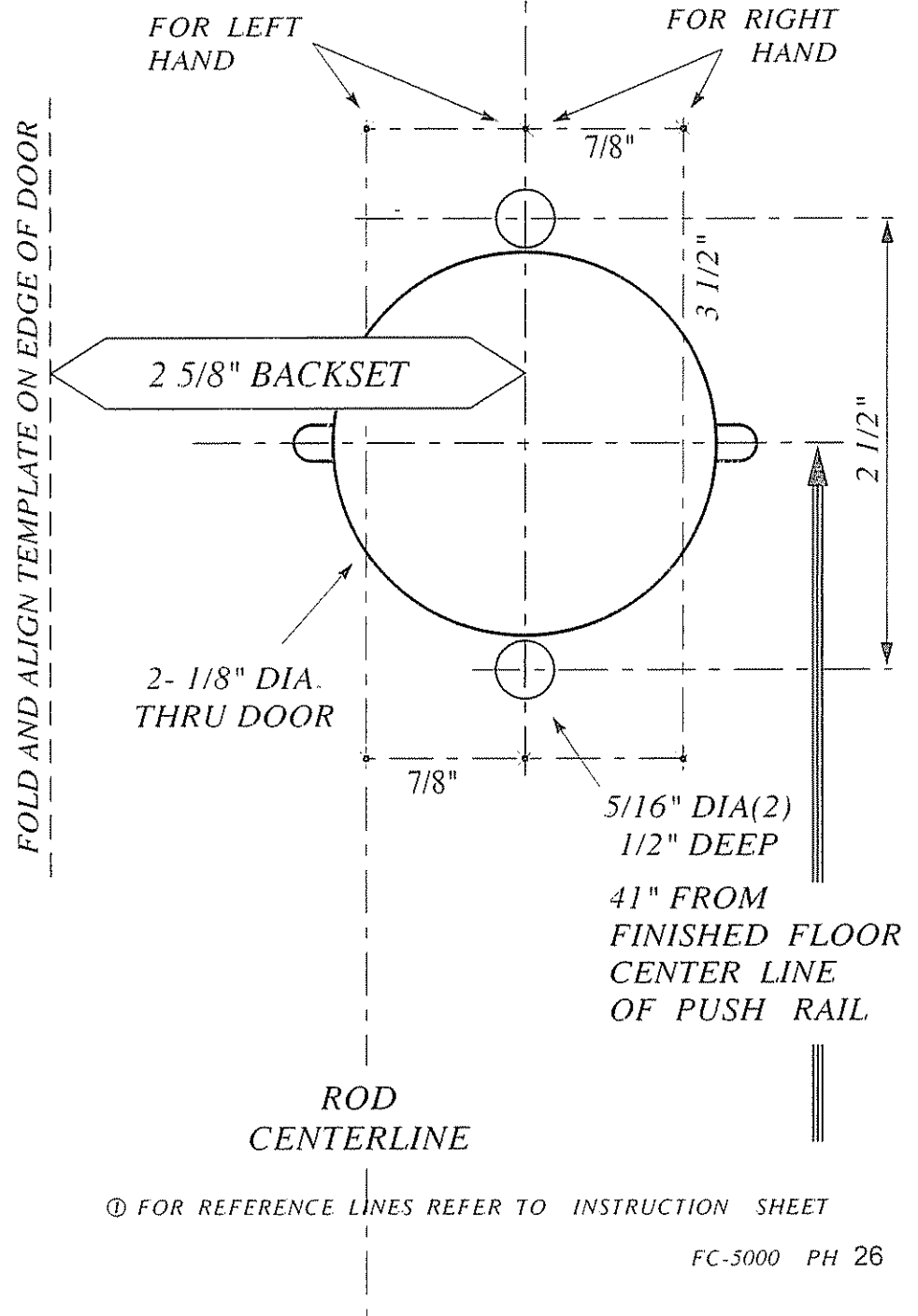

TEMPLATE

FOR EDTBAR AND SVRTBAR SERIES EXIT DEVICE USING LEVER HANDLE TRIM

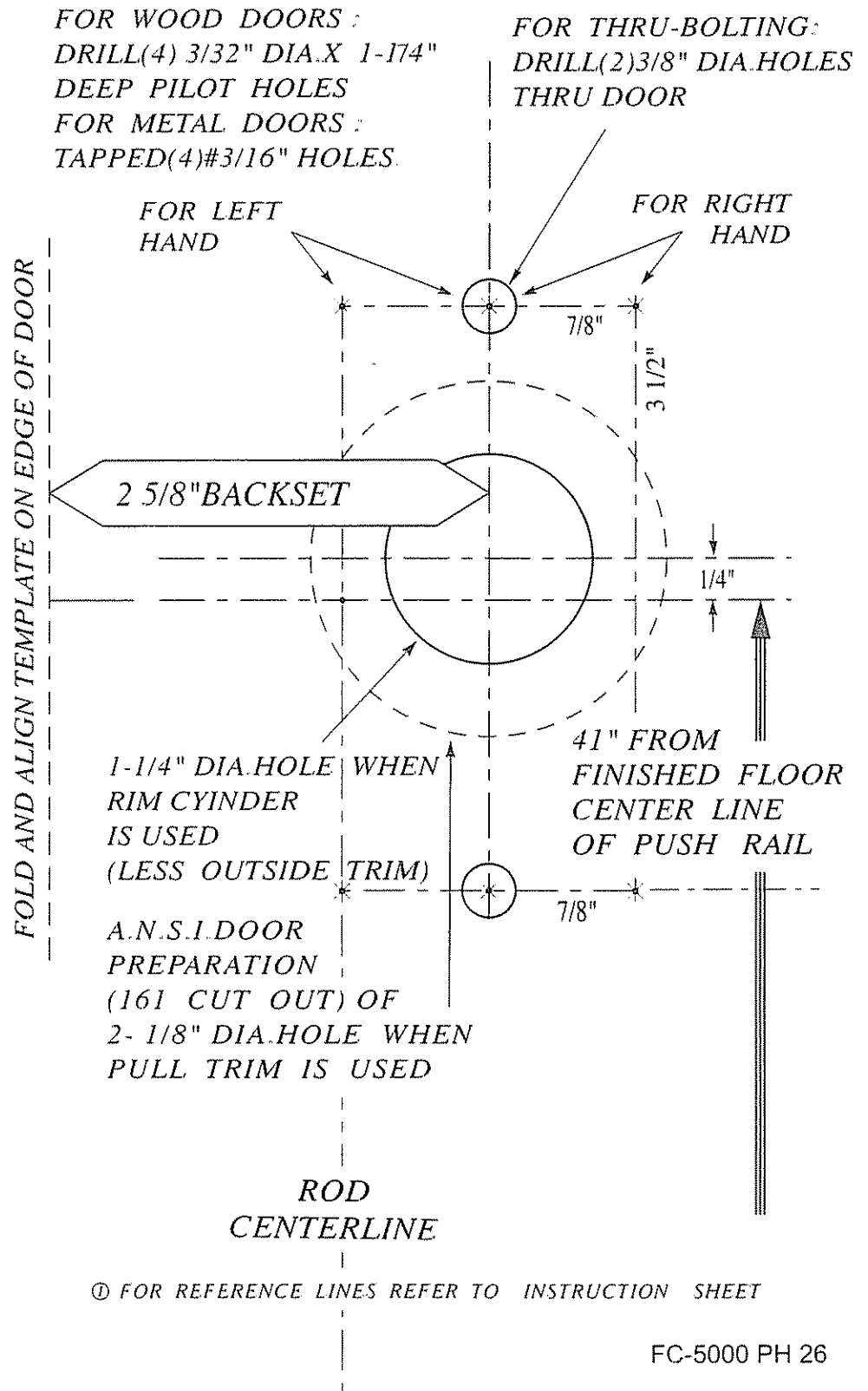

THIS TEMPLATE NOT TO BE USED FOR 881
 MONITOR STRIKE, PREPARE DOOR USING
 INSTRUCTIONS PACKED WITH MONITOR STRIKE

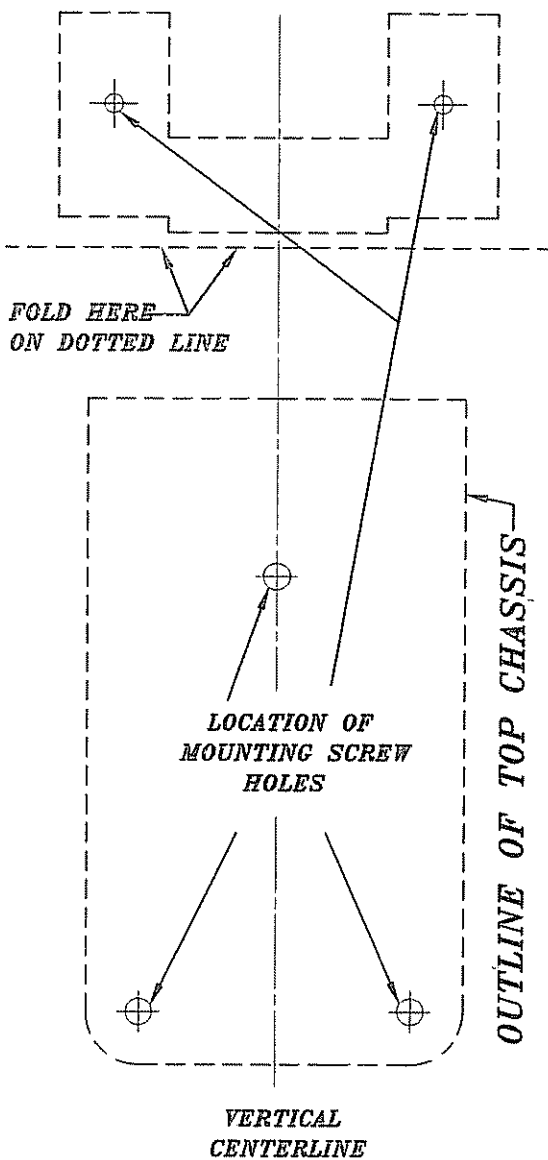

THIS TEMPLATE NOT TO BE USED FOR MONITOR
 STRIKE PREP DOOR USING
 INSTRUCTIONS PACKED
 WITH MONITOR STRIKE

